



ANNALES

DE

L'INSTITUT FOURIER

Pascal COLLIN & Harold ROSENBERG

Asymptotic values of minimal graphs in a disc

Tome 60, n° 7 (2010), p. 2357-2372.

http://aif.cedram.org/item?id=AIF_2010__60_7_2357_0

© Association des Annales de l'institut Fourier, 2010, tous droits réservés.

L'accès aux articles de la revue « Annales de l'institut Fourier » (<http://aif.cedram.org/>), implique l'accord avec les conditions générales d'utilisation (<http://aif.cedram.org/legal/>). Toute reproduction en tout ou partie cet article sous quelque forme que ce soit pour tout usage autre que l'utilisation à fin strictement personnelle du copiste est constitutive d'une infraction pénale. Toute copie ou impression de ce fichier doit contenir la présente mention de copyright.

cedram

*Article mis en ligne dans le cadre du
Centre de diffusion des revues académiques de mathématiques
<http://www.cedram.org/>*

ASYMPTOTIC VALUES OF MINIMAL GRAPHS IN A DISC

by Pascal COLLIN & Harold ROSENBERG

ABSTRACT. — We consider solutions of the prescribed mean curvature equation in the open unit disc of euclidean n -dimensional space. We prove that such a solution has radial limits almost everywhere; which may be infinite. We give an example of a solution to the minimal surface equation that has finite radial limits on a set of measure zero, in dimension two. This answers a question of Nitsche.

RÉSUMÉ. — Nous considérons les solutions de l'équation de la courbure moyenne prescrite sur le disque unité ouvert de l'espace euclidien. Nous prouvons qu'une telle solution a une limite radiale presque partout qui, éventuellement, peut-être infinie. Nous donnons l'exemple d'une solution de l'équation des surfaces minimales en dimension deux, qui admet des limites radiales finies sur un ensemble de mesure nulle. Ce travail répond à une question de Nitsche.

1. Introduction

Let D be the open unit disk $\{(r, \theta) \mid 0 \leq r < 1, 0 \leq \theta \leq 2\pi\}$ and g a Riemannian metric on D . We consider solutions u on D , of the minimal surface equation

$$\operatorname{div} \left(\frac{\nabla u}{W} \right) = 0,$$

where the terms are calculated in the metric g and $W^2 = 1 + |\nabla u|^2$. We remark that $X_u = \frac{\nabla u}{W}$, is the horizontal component of the downward pointing unit normal vector field, to the graph of u in $D \times \mathbb{R}$, with the Riemannian product metric. Our primary interests are when g is the Euclidean metric in D and when g is the (complete) hyperbolic metric in D of curvature -1 .

For fixed θ , we define the radial limit (also called asymptotic value) $u(\theta)$:

$$u(\theta) = \lim_{r \rightarrow 1} u(r, \theta).$$

Keywords: Minimal graphs, radial limits, Fatou theorem.

Math. classification: 53A10, 53C43.

Our main concern is understanding for what values of θ does $u(\theta)$ exist; allowing infinite values as well.

When the minimal surface equation is replaced by the Laplace equation, this is a well studied problem. For example, when g is the Euclidean metric and u is a bounded harmonic function, then Fatou's theorem states radial limits (indeed, even angular limits) exist for almost all θ . Also, in this case, the radial limits can not be plus infinity for a positive measure set of θ .

In 1965, Nitsche asked if there is a Fatou theorem for solutions of the minimal surface equation in the Euclidean disk D [4]. This was answered affirmatively by V. Miklyukov [3]. He proved that angular limits exist almost everywhere, for a solution to the minimal surface equation on a domain bounded by a rectifiable Jordan curve (they may be $\pm\infty$). We prove that radial limits exist almost everywhere (again, they may be $\pm\infty$) for the prescribed mean curvature equation on the n -dimensional unit ball.

THEOREM. — *Let $D = \{x \in \mathbb{R}^{n+1} \mid \|x\| < 1\}$ and let H be a bounded continuous function on D . Let u be a smooth solution of*

$$\operatorname{div} \left(\frac{\nabla u}{W} \right) = 2H$$

on D . Then u has radial limits almost everywhere.

In the same paper [4] Nitsche also asked what is the largest set of θ for which a minimal graph on D may not have radial limits. If one allows infinite radial limits then the Fatou type theorem says the largest set has measure zero. If one means finite radial limits then we will show there is an example with finite radial limits only on a set of measure zero. In this example, the $+\infty$ radial limits (resp. $-\infty$) are taken on a set of measure π (resp. π). Notice that although the value $+\infty$ is taken on a positive measure set of the unit circle, there is no interval on which the value $+\infty$ is assumed. However, when the domain is the interior of a square, the classical doubly periodic solution of Scherk ($\log(\cos(x)/\cos(y))$) takes the values $+\infty$ and $-\infty$ on alternate sides of the square. Thus the asymptotic behavior of solutions depends on the geometry of the boundary.

We conjecture that π is the maximum value for which radial limits in the 2-dimensional disk can be $+\infty$.

Now consider solutions to the minimal surface equation in the hyperbolic metric on the disc. We will give an example for which radial limits do not exist almost everywhere (including infinite limits).

We conjecture that bounded minimal graphs on D , with the hyperbolic metric, do have radial limits almost everywhere.

2. An example in the hyperbolic metric

Let Γ be the ideal polygon in \mathbb{H}^2 whose vertices are the four roots of unity, rotated by 45 degrees. Let D_1 be the convex hull of Γ . Let u_1 be the minimal graph on D_1 which equals one on two opposite sides of Γ and equals zero on the remaining (opposite) sides of Γ . By Schwarz reflection, u_1 extends to an entire minimal graph in D (cf. Figures 2.1 and 2.2).

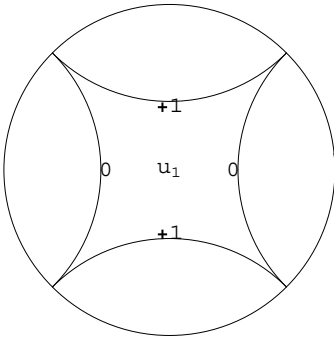

Figure 2.1

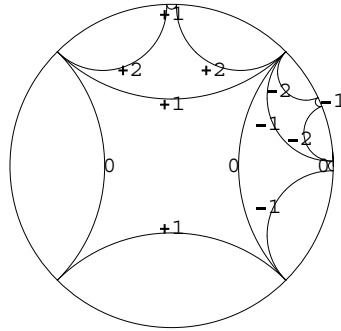

Figure 2.2

By symmetry of D_1 through all the sides of Γ (and then continuing the symmetries through the new sides) the vertices of Γ become a countable dense set V on the unit circle. It is not hard to see that for each θ in the measure 2π set $S^1 - V$, the limit of $u(r, \theta)$ does not exist as $r \rightarrow 1$ ($r \rightarrow \infty$ in the hyperbolic metric).

We analyse the radial limits using ergodic theory.

There is a natural quotient Σ of \mathbb{H}^2 which is a 4-punctured sphere of curvature -1 and finite area. This is indicated in the figure 2.3 where the R -domains are identified by hyperbolic translations (as well as the B -domains, c.f. Figure 2.3).

The geodesic flow on Σ (i.e., on $T_1(\Sigma)$) is ergodic for the Liouville measure, (Hopf proved this is true for any hyperbolic manifold of finite volume). Then the Poincaré recurrence theorem implies that for any open set W of $T_1(\Sigma)$ and for almost all $(p, v) \in W$ there exists $t_n \rightarrow \infty$ so that $\phi_{t_n}(p, v) \in W$; ϕ the geodesic flow on $T_1(\Sigma)$.

Hence for U an open set of Σ and for almost all $p \in U$, and for almost all unit tangent vectors v at p , the geodesic $\gamma_v(p)$ starting at p having v as tangent, returns infinitely often to U . An isometry of Σ sending a point

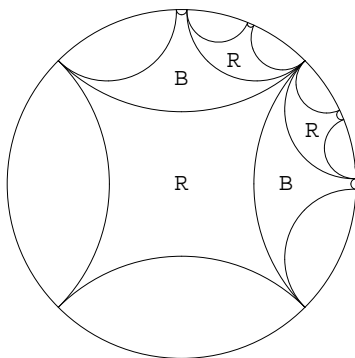

Figure 2.3

p to a point q induces an absolutely continuous map from the fiber over p (in $T_1(\Sigma)$) to the fiber over q . Hence for each point p in U , and for almost all unit tangent vectors v at p , $\gamma_v(p)$, returns to U infinitely often.

Fix an integer n and define

$A_n = \{(p, v) \in T_1(\Sigma) \mid \text{the geodesic } \gamma_v(p) \text{ of } \Sigma \text{ goes at least once to an opposite side, as it traverses } n \text{ fundamental domains of } \Sigma, \text{ starting at } (p, v)\}$.

A_n is open and not empty. Now fix p . Then for almost all unit tangent vectors v at p , the geodesic $\varphi_t(p, v)$ intersects A_n infinitely often. So the geodesic $\gamma_t(p, v)$ traverses opposite sides of a fundamental domain infinitely often. Observe that u varies on an interval of length at least $1/2$ when one traverses a domain by opposite sides. Hence u has no finite limit on this geodesic, and the set of θ for which finite radial limits exist is of measure zero.

Also the geodesics along which $u \rightarrow +\infty$ is an invariant set hence has measure 0 or 1. By symmetry the measure of the set for which $u \rightarrow -\infty$ is the same as the measure for which $u \rightarrow +\infty$. Thus both sets have measure zero.

Hence u has no radial limits almost everywhere.

3. A Fatou Theorem for mean curvature

THEOREM. — *Let $D = \{x \in \mathbb{R}^{n+1} \mid \|x\| < 1\}$ and let H be a bounded continuous function on D . Let u be a smooth solution of*

$$\operatorname{div} \left(\frac{\nabla u}{W} \right) = 2H$$

on D . Then u has radial limits almost everywhere.

Proof. — Let $f: \mathbb{R} \rightarrow (-1, +1)$ be smooth and $0 < f'(x) < 1$ for all $x \in \mathbb{R}$ (e.g., $f(x) = \frac{2}{\pi} \arctan(x)$). Define $\varphi = f \circ u$, and $X = \frac{\nabla u}{W}$; X is a vector field on D with norm less than one and divergence equal to $2H$.

We have

$$\begin{aligned} \operatorname{div}(\varphi X) &= \varphi \operatorname{div} X + \langle \nabla \varphi, X \rangle \\ &= 2H \varphi + f'(u) \langle \nabla u, X \rangle \\ &= 2H \varphi + f'(u) \left(W - \frac{1}{W} \right) \\ &= 2H \varphi - \frac{f'(u)}{W} + f'(u)W. \end{aligned}$$

By Stokes theorem:

$$\int_{D(r)} \operatorname{div}(\varphi X) = \int_{\partial D(r)} \varphi \langle X, \nu \rangle,$$

for $r < 1$ and ν the outer conormal to $\partial D(r)$. Since $|\varphi \langle X, \nu \rangle| \leq 1$, we have

$$\int_{D(r)} \operatorname{div}(\varphi X) \leq \omega_n, \quad \omega_n \text{ the volume of } S^n \equiv \partial D.$$

Since $2H \varphi - \frac{f'(u)}{W}$ is bounded on D , and $f'(u)W \geq 0$, we conclude

$$\int_D f'(u)W < \infty.$$

We have $f'(u)|\nabla u| \leq f'(u)W$, and $|\nabla \varphi| = f'(u)|\nabla u|$, thus $|\nabla \varphi|$ is integrable on D . Since $\frac{\partial \varphi}{\partial r} \leq |\nabla \varphi|$, we have (Fubini):

$$\int_D \frac{\partial \varphi}{\partial r} = \int_{\omega \in S^n} \left(\int_{r=0}^1 \frac{\partial \varphi}{\partial r} r^{n-1} dr \right) d\omega < \infty.$$

Thus, for almost all $\omega \in S^n$,

$$\int_{r=0}^1 \frac{\partial \varphi}{\partial r}(r, \omega) dr < \infty,$$

and $\lim_{r \rightarrow 1} \varphi(r, \omega)$ exists for almost all ω .

Since $\varphi = f \circ u$, we conclude u has radial limits almost everywhere (which may be $\pm\infty$ if φ tends to ± 1). □

4. Nitsche's Second Question

We now construct an example of a minimal graph in the Euclidean disk $D = \{x^2 + y^2 < 1\}$ for which the finite radial limits are of measure zero. This construction is inspired by the example in the authors paper [1].

We recall the Jenkins-Serrin theorem for polygons in \mathbb{R}^2 .

THEOREM ([2]). — Let $\Gamma \subset \mathbb{R}^2$ be a compact polygon with an even number of sides $A_1, B_1, A_2, B_2, \dots, A_n, B_n$, in that order, and denote by D the domain with $\partial D = \Gamma$. The necessary and sufficient conditions for the existence of a minimal graph u on D , taking the values $+\infty$ on each A_i , and $-\infty$ on each B_j , are the following 2 conditions.

- (1) $\sum_{i=1}^n |A_i| = \sum_{j=1}^n |B_j|$,
- (2) for each inscribed polygon P in D (the vertices of P are among the vertices of Γ) $P \neq D$, one has the two inequalities:

$$2a(P) < |P| \quad \text{and} \quad 2b(P) < |P|.$$

Here $a(P) = \sum_{A_j \in P} |A_j|$, $b(P) = \sum_{B_i \in P} |B_i|$ and $|P|$ is the perimeter of P .

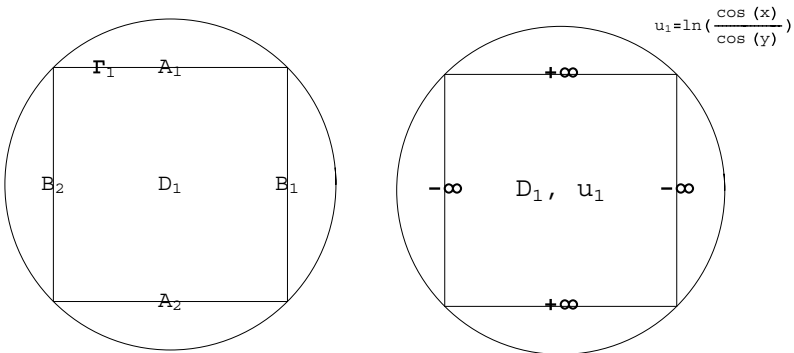

Figure 4.1

We can now begin the example. Let D_1 be the square inscribed in $S^1 = \partial D$, whose vertices are the four roots of unity rotated by 45 degrees, and let $\Gamma_1 = \partial D_1$. There is a minimal graph u_1 in D_1 which is $+\infty$ on the two horizontal sides of D_1 and equals $-\infty$ on the two vertical sides (Scherk wrote an explicit formula for u_1 , which is written in Figure 4.1 above, for a certain square of side length π). We label the sides of Γ_1 as A_1, B_1, A_2, B_2 , -clockwise-, with A_1 the top side (cf. Figure 4.1).

Henceforth we will attach “regular trapezoids” to the sides of a polygon Γ . By this we mean a quadrilateral E attached to a side β of Γ so that the side of Γ opposite β , is parallel to β , and the sum of the lengths of opposite sides of E are equal; Figure 4.2.

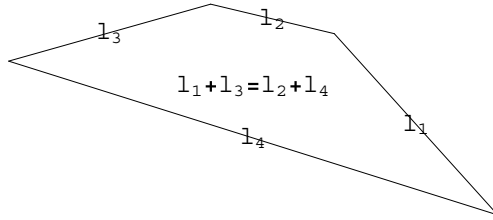

Figure 4.2

Let E and E' be regular trapezoids attached to A_1 and B_1 respectively so that all the vertices of E and E' are on S^1 (cf. Figure 4.3).

We remark that such a regular E exists since when the top edge of E is very close to A_1 , then the sum of the lengths of the horizontal sides is greater than the sum of the lengths of the other two sides. When the top side is near the top of S^1 , then the sum of the lengths is less than the sum of the lengths of the non-parallel sides (triangle inequality). Hence there is a unique position of the top chord of E for which one has equality.

Consider the domain $D_2 = D_1 \cup E \cup E'$, $\Gamma_2 = \partial D_2$. This new domain does not satisfy the second condition of the Jenkins-Serrin theorem: the inscribed polygons E , E' and their complements are not admissible. For example, for E , the equality $2a(E) = |E|$ holds and for E' , $2b(E') = |E'|$, violating the 2nd condition: (cf. Figure 4.4).

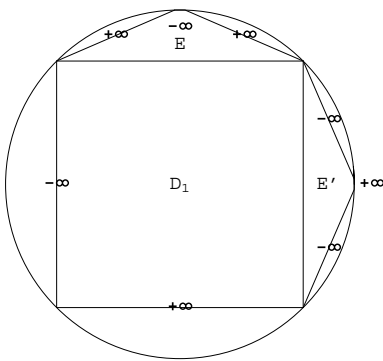

Figure 4.3

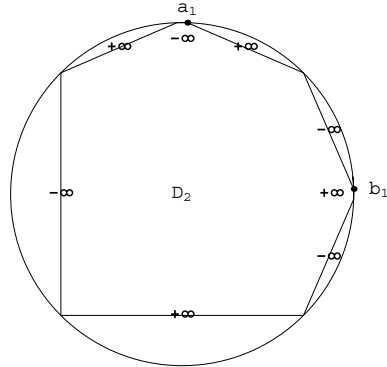

Figure 4.4

We perturb D_2 to made it admissible (i.e., the two conditions of Jenkins-Serrin are satisfied). One moves the vertex a_1 towards b_1 to a nearby point $a_1(\tau)$ on S^1 (making the $+\infty$ sides of E shorter and the $-\infty$ side longer),

and then one moves b_1 towards a_1 to a nearby point $b_1(\tau)$ on S^1 (making the $-\infty$ sides of E' shorter and the $+\infty$ side longer). Let $\Gamma_2(\tau)$ be the inscribed polygon obtained by this perturbation. For each $\tau > 0$, τ small, one can choose the $a_1(\tau)$ and $b_1(\tau)$ so that $\Gamma_2(\tau)$ satisfies condition 1 of Jenkins-Serrin (cf. Figure 4.5).

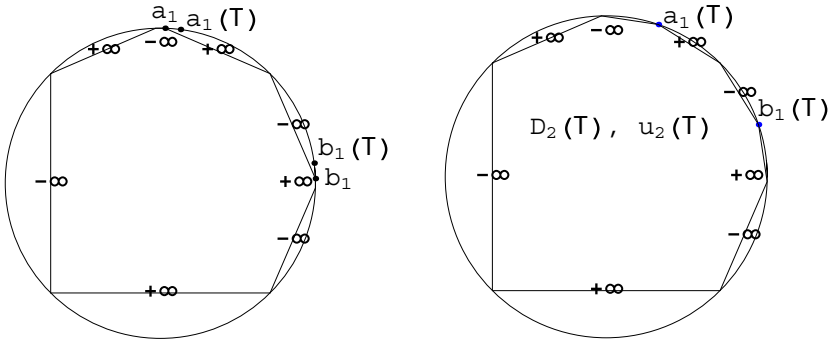

Figure 4.5

By construction, one has

$$2a(E(\tau)) < |E(\tau)| \text{ and } 2b(E'(\tau)) < |E'(\tau)|.$$

For $D_2(\tau)$ to be an admissible domain, one must check the above inequalities for all other inscribed polygons in $D_2(\tau)$, distinct from $D_2(\tau)$. We will prove this in general. The section that follows is like Section 6 of [1].

5. Extending Scherk Surfaces

Let (d_1, d_2, \dots, d_n) be n distinct points of S^1 , ordered clockwise, and denote by $P(d_1, d_2, \dots, d_n)$ the convex hull of these points (in the Euclidean metric). When n is even we make the convention that Scherk graphs on $P(d_1, d_2, \dots, d_n)$ take the value $+\infty$ on the sides $[d_i, d_{i+1}]$, i even, and $-\infty$ on the other sides when i is odd. Let A_i denote the side $[d_{2i}, d_{2i+1}]$ and B_i the side $[d_{2i+1}, d_{2i+2}]$. We say $P(d_1, d_2, \dots, d_n)$ is a Scherk domain (or admissible) if its boundary satisfies the two Jenkins-Serrin conditions; so Scherk graphs exist on the domain. They are unique up to a vertical translation.

PROPOSITION. — Let u be a Scherk graph on a polygonal domain $D_1 = P(a_1, a_2, \dots, a_{2k})$ (inscribed in the unit circle) and K be a compact set in the interior of D_1 . Let $D_2 = P(b_1, b_2, a_1, b_3, b_4, a_2, \dots, a_{2k})$ be the polygonal domain D_1 to which we attach two regular trapezoids $E = P(b_1, b_2, a_1, a_0)$ and $E' = P(a_1, b_3, b_4, a_2)$; E is attached to the side $[a_0, a_1]$ of D_1 and E' to the side $[a_1, a_2]$.

Then for all $\varepsilon > 0$, there exists $(b'_i)_{i=2,3}$ and v a Scherk graph on $P(b_1, b'_2, a_1, b'_3, b_4, a_2, \dots, a_{2k})$ such that:

$$|b'_i - b_i| \leq \varepsilon \text{ and } \|v - u\|_{C^2(K)} \leq \varepsilon.$$

The proof of this proposition is rather long and is essentially contained in our paper [1] from lemma 4 on. However there are some differences. First we no longer need horocycles to define lengths; but this is not important here. Secondly, in [1], we attached regular quadrilaterals, all of whose sides have equal length, and then we perturbed the polygons. Now the lengths of the sides are not equal; the trapezoids are “balanced”. For this reason we will do the proof that the perturbed polygon $D'_2 = P(b_1, b'_2, a_1, b'_3, b_4, a_2, \dots, a_{2k})$ is a Scherk domain.

The idea is to show that D_2 satisfies the Jenkins-Serrin conditions except for some particular inscribed polygons. Then by a small variation of $(b_i)_{i=2,3}$ we can ensure the conditions are satisfied for all inscribed polygons. The inscribed polygons that satisfy the strict inequalities of condition 2, continue to satisfy the strict inequality for small perturbations.

LEMMA. — All the inscribed polygons of D_2 are admissible except the boundaries of E, E' , and their complements $D_1 - E, D_1 - E'$.

Proof. — For the entire polygon D_2 , a simple computation gives that $a(\Gamma_2) = b(\Gamma_2)$, where $\Gamma_2 = \partial D_2$; this is why we attached regular trapezoids. Thus it suffices to prove the second Jenkins-Serrin inequality for a inscribed polygon \mathcal{P} , distinct from E, E' and their complements. Notice that by symmetry of the problem, we need only prove the second inequality for values $+\infty$ on the boundary.

So let \mathcal{P} be an inscribed polygon in D_1 as above ($\neq E, E'$, and their complements), and let $\mathcal{P} = \partial P(d_1, \dots, d_n)$, where $(d_i)_{i=1, \dots, n}$ are vertices of D_1 . We want to prove $|\mathcal{P}| > 2a(\mathcal{P})$.

Let $P' = P - E'$ and $\mathcal{P}' = \partial P'$. □

CLAIM. — if $|\mathcal{P}'| > 2a(\mathcal{P}')$ then $|\mathcal{P}| > 2a(\mathcal{P})$.

Once this claim is established it will be enough to prove $|\mathcal{P}'| > 2a(\mathcal{P}')$.

Proof of the Claim. — if $\mathcal{P}' = \mathcal{P}$ the result is obvious, otherwise the chord $[b_3, b_4]$ where $v = +\infty$ is in \mathcal{P} . Write $\mathcal{P} = \partial P(d_1, b_3, b_4, d_2, \dots, d_n)$.

Let $q_1 = [d_1, b_3] \cap [a_1, a_2]$ and $q_2 = [d_2, b_4] \cap [a_1, a_2]$. Notice that if $a_1 \in \mathcal{P}$ (resp. $a_2 \in \mathcal{P}$) then $q_1 = a_1$ and $|a_1 q_1| = 0$ by convention (resp. $q_2 = a_2$ and $|q_2 a_2| = 0$) cf. Figure 5.1. We have

$$a(\mathcal{P}) = a(\mathcal{P}') + |b_3 b_4|$$

$$|\mathcal{P}| = |\mathcal{P}'| - |q_1 q_2| + |q_1 b_3| + |b_3 b_4| + |b_4 q_2|.$$

Using the regularity:

$$|a_1 q_1| + |q_1 q_2| + |q_2 a_2| + |b_3 b_4| = |a_1 b_3| + |b_4 a_2|$$

and substituting the above values of $a(\mathcal{P})$ and $|\mathcal{P}|$, we have

$$\begin{aligned} |\mathcal{P}| - 2a(\mathcal{P}) &= |\mathcal{P}| - 2(a(\mathcal{P}') + |b_3 b_4|) \\ &= |\mathcal{P}'| - |q_1 q_2| + (|q_1 b_3| + |b_3 b_4| + |b_4 q_2|) \\ &\quad - 2a(\mathcal{P}') - 2|b_3 b_4| > |q_1 b_3| + |q_2 b_4| - (|b_3 b_4| + |q_1 q_2|) \end{aligned}$$

(since $|\mathcal{P}'| > 2a(\mathcal{P}')$)

$$\begin{aligned} &= |q_1 b_3| + |q_2 b_4| - (|a_1 b_3| + |b_4 a_2| - |a_1 q_1| - |q_2 a_2|) \\ &= (|a_1 q_1| + |q_1 b_3| - |a_1 b_3|) + (|a_2 q_2| + |q_2 b_4| - |a_2 b_4|) > 0, \end{aligned}$$

by the triangle inequality. This proves the claim. □

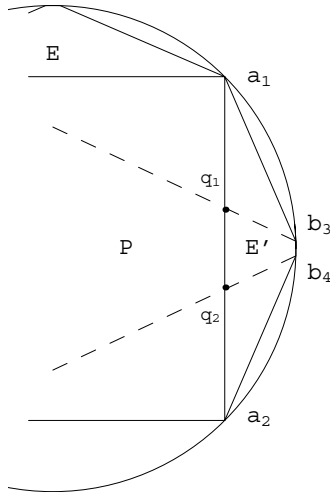

Figure 5.1

Now it remains to prove $|\mathcal{P}'| > 2a(\mathcal{P}')$. For that define $\mathcal{P}'' = \mathcal{P}' - E$, $\mathcal{P}'' = \partial\mathcal{P}''$, and $I_1 = \mathcal{P}'' \cap [a_0, a_1]$. A flux calculation shows that

$$|\mathcal{P}''| - 2(a(\mathcal{P}'') + |I_1|) > 0;$$

we refer the reader to [1].

Now there are several cases to consider.

Case 1. Suppose $[a_0, b_1] \cup [b_2, a_1] \subset \mathcal{P}$. Then $E \subset \mathcal{P}'$ and

$$\begin{aligned} a(\mathcal{P}') &= a(\mathcal{P}'') + |a_0b_1| + |b_2a_1|, \\ |\mathcal{P}'| &= |\mathcal{P}''| - |a_0a_1| + |a_0b_1| + |b_1b_2| + |b_2a_1|, \\ |I_1| &= |a_0a_1|; \end{aligned}$$

Substitute in the flux inequality:

$$\begin{aligned} 0 &< |\mathcal{P}'| + |a_0a_1| - |a_0b_1| - |b_1b_2| - |b_2a_1| \\ &\quad - 2(a(\mathcal{P}') - |a_0b_1| - |b_2a_1| + |a_0a_1|) \\ &= |\mathcal{P}'| - 2a(\mathcal{P}') - |a_0a_1| + |a_0b_1| + |b_2a_1| - |b_1b_2| \\ &= |\mathcal{P}'| - 2a(\mathcal{P}'). \end{aligned}$$

The last equality because E is regular.

Case 2. Suppose only one of the $[a_0, b_1]$ or $[b_2, a_1]$ is contained in \mathcal{P} ; $[a_0, b_1]$ say. Let $I_1 = [a_0, q]$. There are two possibilities: the segment $[q, b_1]$ is in $\partial\mathcal{P}$, or the segment $[q, b_2] \subset \partial\mathcal{P}$. We do the estimate for the latter case and leave the first for the reader.

We have:

$$\begin{aligned} a(\mathcal{P}') &= a(\mathcal{P}'') + |a_0b_1| \\ |\mathcal{P}'| &= |\mathcal{P}''| - |I_1| + |a_0b_1| + |b_1b_2| + |b_2q|. \end{aligned}$$

Then substituting in the flux inequality:

$$\begin{aligned} 0 &< (|\mathcal{P}'| + |I_1| - |a_0b_1| - |b_1b_2| - |b_2q|) \\ &\quad - 2(a(\mathcal{P}') - |a_0b_1| + |I_1|) \\ &= |\mathcal{P}'| - 2a(\mathcal{P}') - |b_1b_2| - |b_2q| + |a_0b_1| - |I_1|. \end{aligned}$$

The two triangle inequalities:

$$\begin{aligned} |a_0b_1| &< |a_0q| + |qb_1| \\ |b_1q| &< |b_1b_2| + |b_2q|, \end{aligned}$$

show that the term

$$-|b_1b_2| - |b_2q| + |a_0b_1| - |I_1|$$

is negative. Hence

$$0 < |\mathcal{P}'| - 2a(\mathcal{P}'), \text{ as desired.}$$

Case 3. The remaining case is for $P' \subset D_1$. Then the flux inequality gives the result for $\mathcal{P}' = \partial P'$.

This completes the proof of the lemma.

For the rest of the proof of the proposition we refer the reader to Lemma 5 and the proof of Proposition 2 of our paper [1].

Now we return to the square D_1 inscribed in S^1 , at the four roots of unity rotated by 45 degrees, and the Scherk graph u_1 on D_1 , u_1 is $+\infty$ on the horizontal sides of ∂D_1 and $-\infty$ on the vertical sides. Let K be the square in D_1 , which is the image of \bar{D}_1 by homothety from the origin by some constant $a < 1$; $K = a \cdot \bar{D}_1$.

Let $B = \{p \in \mathbb{R}^2 \mid |p - z_i| < 1 - a, z_i, i = 1, \dots, 4, \text{ the vertices of } D_1 \}$.

Finally, let $K_1 = K - B$; cf. Figure 5.2.

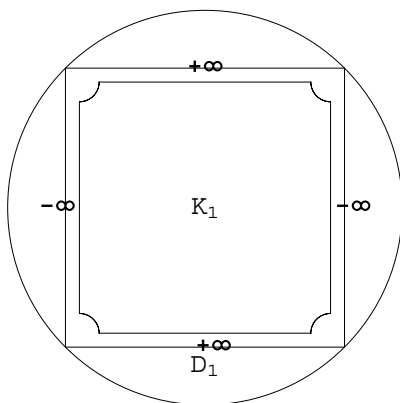

Figure 5.2

We choose a close enough to 1, so that $u_1 > 1$ on the horizontal sides of K_1 , and $u_1 < -1$ on the vertical sides of K_1 .

Next consider the domains $D_2(\tau) = D_1 \cup E(\tau) \cup E'(\tau)$ we constructed. We have seen that we can choose $\tau_2 > 0$ so that for $0 < \tau \leq \tau_2$, $u_2(\tau)$ is as close as we want to u_1 on K_1 . We take τ_2 so that $u_2(\tau) > 1$ on the horizontal sides of K_1 and $u_2(\tau) < -1$ on the vertical sides of K_1 . Also we can take $u_2(\sigma) = u_1(\sigma)$, where σ is the center of the circle. More precisely, for any $\varepsilon_2 > 0$ there exists $\tau_2 > 0$ such that for $0 < \tau \leq \tau_2$, $u_2(\tau)$ exists, $u_2(\sigma) = u_1(\sigma)$ and

$$\|u_1 - u_2(\tau)\|_{K_1, C^2} \leq \varepsilon_2.$$

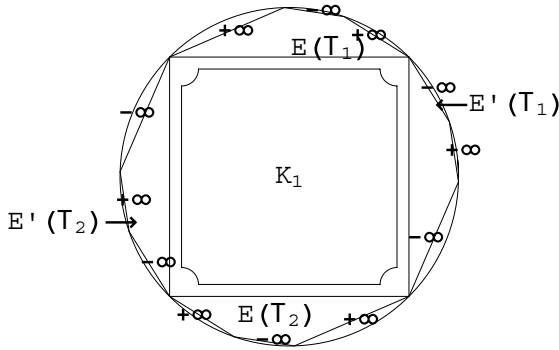

Figure 5.3

Then choose $\varepsilon_2 > 0$, so that $u_2(\tau) > 1$ on the horizontal sides of K_1 and $u_2(\tau) < -1$ on the vertical sides, for all $\tau, 0 < \tau \leq \tau_2$.

Let $K_2(\tau) \subset D_2(\tau)$ be a compact domain composed of sides parallel to the sides of $\partial D_2(\tau)$ (and “close” to the sides of $\partial D_2(\tau)$) together with circular arcs centered at the vertices of $\partial D_2(\tau)$. We believe the Figure 5.4 suffices to define $K_2(\tau)$ (up to size):

We indicate the boundary values of $u_2(\tau)$ on the Figure 4.5.

Choose $K_2(\tau)$ close enough to $\partial D_2(\tau)$, so that for $0 < \tau \leq \tau_2, u_2(\tau) > 2$ on those sides (which do not already belong to ∂K_1) of $\partial K_2(\tau)$ parallel to sides of $D_2(\tau)$ where $u_2(\tau) = +\infty$, and $u_2(\tau) < -2$ on the sides of $\partial K_2(\tau)$ (again, those which do not already belong to ∂K_1) parallel to sides of $\partial D_2(\tau)$ where $u_2(\tau) = -\infty$.

Next construct the Scherk domain $D_3(\tau)$ by attaching perturbed regular trapezoids to the remaining two sides A_2 and B_2 of D_1 . We know that there exists $\tau_3 > 0$ such that if $0 < \tau \leq \tau_3$ then a Scherk graph $u_3(\tau)$ exists, $u_3(\sigma) = u_1(\sigma)$, and

$$\|u_3(\tau) - u_2(\tau)\|_{K_2(\tau), C^2} < \varepsilon_3.$$

Here ε_3 is chosen small enough so that $u_3(\tau) > 3$ on the sides of $\partial K_2(\tau)$ parallel to the sides of $D_2(\tau)$ where $u_2(\tau) = +\infty$ and $u_3(\tau) < -3$ on the sides parallel to the sides where $u_2(\tau) = -\infty$.

Now choose $\varepsilon_n \rightarrow 0, \tau_n \rightarrow 0, K_n(\tau_n)$ so that $K_n(\tau_n) \subset K_{n+1}(\tau_{n+1}), \bigcup_n K_n(\tau_n) = D$.

Let B_n be the length of the circular sides of $K_n(\tau_n)$. We know we can choose $K_n(\tau_n)$ so that $B(n)$ is as small as we wish. We choose $K_n(\tau_n)$ so that there is a number $c, 0 < c < 1$, and $B_{n+1} \leq c B_n$. Thus the set

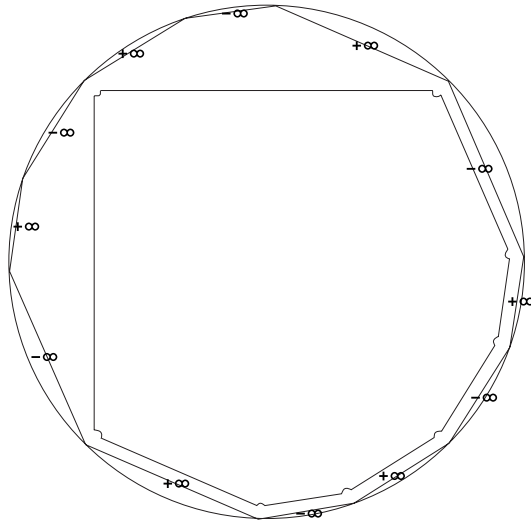

Figure 5.4

$\{\theta : r e^{i\theta}$ traverses an infinite number of circle arcs of $\bigcup_n K_n(\tau_n)$, as $r \rightarrow 1\}$ has measure zero.

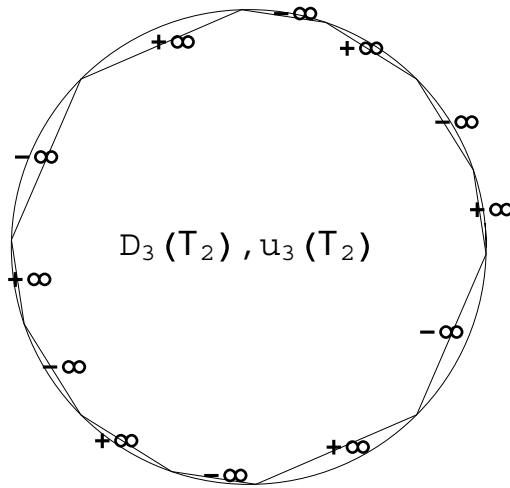

Figure 5.5

The $u_n(\tau_n)$ converge to a minimal graph u on D . We will now see that u has the desired properties: the radial limits are finite on a set of measure zero, they are $+\infty$ (resp. $-\infty$) on a set of measure π .

Let F be the set of vertices of the quadrilaterals $E_n(\tau_n)$, $n = 1, 2, \dots$. F is a countable dense set of measure zero on S^1 . Let θ be in the measure 2π set V where $\lim_{r \rightarrow 1} u(r, \theta)$ exists and $\theta \in S^1 - F$ (V exists by our Fatou Theorem). We consider the segment $\ell_\theta = \{re^{i\theta} \mid 0 \leq r < 1\}$.

We can assume each θ in the measure 2π set V satisfies ℓ_θ intersects at most a finite number of circle arcs of $\bigcup_n K_n(\tau_n)$ (since the set of θ such that the ray ℓ_θ intersects an infinite number of circle arcs has measure zero).

Label the quadrilaterals ℓ_θ traverses as $r \rightarrow 1$ in the order they are traversed, E_1, E_2, \dots . When ℓ_θ first intersects E_n , it then leaves E_n by traversing the opposite side or it leaves E_n by traversing one of the two adjacent sides.

Consider the θ in V such that ℓ_θ traverses an infinite number of E_n crossing to the opposite side of E_n . For n large, ℓ_θ traverses E_n going from one side of E_n to the opposite side of E_n , and near these crossing points, ℓ_θ intersects straight line segments of a $K_m(\tau_m)$ ($m = n$ and $m = n + 1$). So, u takes a value on ℓ_θ greater than n near one crossing point and less than $-n$ near the other crossing point. So, the variation of u on E_n is at least $2n$. Hence u has no finite limit on this ℓ_θ .

Now consider those θ in V such that ℓ_θ crosses E_n by going to an adjacent side of E_n , for n sufficiently large. Then either u takes the values n and $n + 1$ near the adjacent sides, or u always takes the values $-n$ and $-n - 1$ near the adjacent sides (which one depends on whether the first intersection of ℓ_θ and E_1 is a horizontal or vertical side of E_1). Since the radial limits of u exist in V , they must be plus infinity in the first case and minus infinity in the second case.

By symmetry of the plus and minus infinity limits, we conclude that u has radial limits plus infinity (respectively, minus infinity) on a set of measure π . This completes the proof.

Remark. — This example may lead one to believe that the plus infinity radial limits must be balanced by the minus infinity radial limits. However, there is an example of a minimal graph in the (Euclidean) disk that is positive and has plus infinity radial limits on a set of positive measure. We do not know how big this positive measure may be.

BIBLIOGRAPHY

[1] P. COLLIN & H. ROSENBERG, “Construction of harmonic diffeomorphisms and minimal graphs”, To appear in *Annals of Math.*
 [2] H. JENKINS & J. SERRIN, “Variational problems of minimal surface type II. Boundary value problems for the minimal surface equation”, *Arch. Rational Mech. Anal.* **21** (1966), p. 321-342.

- [3] V. MIKYUKOV, “Two theorems on boundary properties of minimal surfaces in non-parametric form”, *Math. Notes* **21** (1977), p. 307-310.
- [4] J. NITSCHKE, “On new results in the theory of minimal surfaces”, *B. Amer. Math. Soc.* **71** (1965), p. 195-270.

Manuscrit reçu le 2 octobre 2009,
accepté le 23 novembre 2009.

Pascal COLLIN
Institut de Mathématiques de Toulouse
Université Paul Sabatier
118, route de Narbonne
31062 Toulouse Cedex 9 (France)
collin@math.ups-tlse.fr

Harold ROSENBERG
IMPA,
22460-320 Estrada Dona Castorina 110
Rio de Janeiro (Brasil)
rosen@impa.br